

# IMPULSE

**MAHLE**

Mobility magazine  
for the  
workshop

01 // 2021  
**EURO 4.50**

—  
**ALWAYS ON  
THE BALL**

Innovative solutions  
for maintenance  
and service

—  
**THE LEAN  
MACHINE**

MAHLE's light,  
powerful e-bike  
drive system

—  
**MORE DRIVES,  
MORE A/C,  
MORE SERVICE**

A/C service today,  
thermal management  
tomorrow

—  
**GREAT  
WORK!**

You're doing a fantastic job.  
And that's why we want to say thank you!





From professional to professional,

We want to thank you for doing a great job. That's why MAHLE says "GREAT WORK!" This is an expression of our appreciation for the mechanics around the globe who deliver excellence every day. After all, while our personal freedom of movement is currently limited, you're keeping us mobile so that society can continue to function. That's why, on page 7, we're giving away an unbeatable knowledge transfer opportunity and the chance to benefit from the experience of our technical experts. It's well worth taking part!

MAHLE Aftermarket sees itself as your strong partner. We do our part so that you can do your job professionally and safely. One example is OzonePRO, our mobile device for the hygienic cleaning of vehicle cabins and other premises—and it's effective against coronaviruses too.

In this issue, in addition to our technical tips, you'll find interesting topics from the MAHLE world, such as the e-bike drive system from MAHLE SmartBike Systems—it's ahead of the pack in a very real sense.

We hope you enjoy reading it—and good luck!

Olaf Henning  
Corporate Executive Vice President and  
General Manager MAHLE Aftermarket

# CONTENTS

## MAHLE INSIDE

- 04** GREAT WORK!  
You're doing a fantastic job, so we want to say thank you!
- 08** A UNIQUE COMBINATION FOR GREAT WORK  
We know what we're talking about!
- 20** ALWAYS ON THE BALL  
Innovative solutions for maintenance and service
- 28** THE LEAN MACHINE  
MAHLE's light, powerful e-bike drive system
- 32** PERFECT CONNECTION  
The new charging cable in original equipment quality
- 34** TEAMWORK: MAN AND MACHINE  
Autonomous forklifts as new colleagues

## DO IT & GET IT

- 12** MORE DRIVES, MORE A/C, MORE SERVICE  
A/C service today, thermal management tomorrow
- 26** LOUIS RECOMMENDS  
Filters belong in the spotlight!
- 30** KING OF THE ROAD: YESTERDAY AND TODAY  
Engine components for trucks

## SWEAT & GASOLINE

## NEW ON THE MARKET

- 36** NEW ON THE MARKET  
More selection, more quality, more efficiency
- 38** AFTERBURNER  
Hot topics and latest news



**04**

**GREAT WORK!**



**28**

**THE LEAN MACHINE**

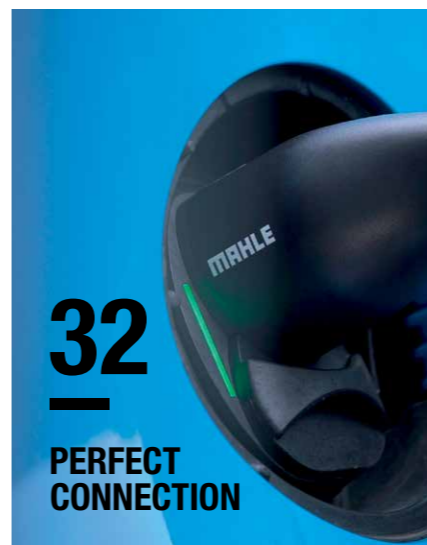

**32**

**PERFECT CONNECTION**



**20**

**ALWAYS ON THE BALL**

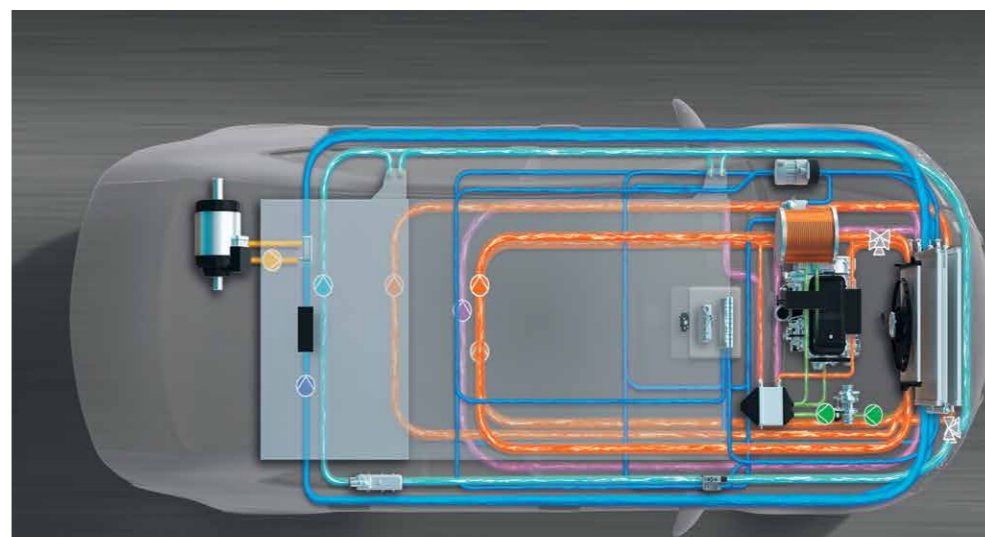

**12**

**MORE DRIVES, MORE A/C, MORE SERVICE**

Register now at [mpulse.mahle.com](http://mpulse.mahle.com), and get your subscription delivered to your door free of charge.



# GREAT WORK!

It's obvious that rescue vehicles save lives. It's obvious that garbage trucks dispose of garbage. And it's obvious that meals on wheels are delivered to customers at 12 o'clock on the dot. Why is that? Because you make the obvious possible. You make mobility possible. Hour after hour, day after day, year after year. We think you're doing a fantastic job. And that's why we want to say thank you!



»GREAT WORK!

# GREAT WORK! SUPPORTED BY MAHLE

## We believe that great work calls for first-class support.

The automotive industry is undergoing rapid change. That's why you're in demand: with a cool head when things get complicated, a high degree of flexibility when you're needed, and new knowledge about the mobility of tomorrow.

MAHLE's got your back: with the right products and a comprehensive service—from thermal management, engine components, and filters to workshop equipment & diagnostics. You can rely on us: products "Made by MAHLE" are always 100 percent brand quality, regardless of the country in which they're manufactured.

### » Thermal Management

A workshop tuned for the future is equipped for the demands that new drive concepts place on engine cooling and air conditioning. We guide and accompany you safely, quickly, and easily through the world of thermal management.

### » Engine components for all drive types

You will continue to receive first-class parts from the leading original equipment manufacturer: pistons, piston ring sets, cylinder liners, bearings, valve train components, turbochargers, and seals. Added to these are starter motors and alternators, and—in the field of e-mobility—actuators and switches, sensors, power electronics, and electric drive systems.

### » Filters

Reliable filtration is timeless and remains important regardless of the type of drive: whether it's powered by a combustion engine, electricity, natural gas, or solar energy. And that's why MAHLE already offers pioneering filtration solutions for alternative drives, such as fuel cell and high-voltage battery systems, in addition to filters for conventional vehicles.

### » Service Solutions

The increasing volume of data in vehicles is opening up opportunities for new business. MAHLE offers a comprehensive range of workshop equipment for maintenance and diagnostics—for example, for the calibration of driver assistance systems.

**WITH THESE SOLUTIONS, WE SUPPORT YOUR GREAT WORK. GREAT WORK—IT'S WHAT YOU DO EVERY DAY. WE PROVIDE YOU WITH EVERYTHING YOU NEED: QUICKLY, RELIABLY, AND WORLD-WIDE—ALL IN HIGH QUALITY.**



## COMPETITION—FANTASTIC PRIZES FOR GREAT WORK

We would like to say **THANK YOU**, and that is why we are offering all participants the chance to win a trip to Germany including a visit to the engine test lab and technical training for the entire workshop team.

» Second and third prizes: technical training either on site or online, whichever you prefer.

Go online and take part! You'll find the terms and conditions of participation and entry form at [mpulse.mahle.com](https://mpulse.mahle.com).

Good luck! Closing date for entries: May 31, 2021.



&gt;&gt; GREAT WORK!

# A UNIQUE COMBINATION FOR GREAT WORK

MAHLE is a leading international development partner and supplier to the automotive industry as well as a pioneer and technology driver for the mobility of tomorrow. It's not just the vehicle manufacturers who benefit from this unique knowledge—most of all, it's you and your workshop.

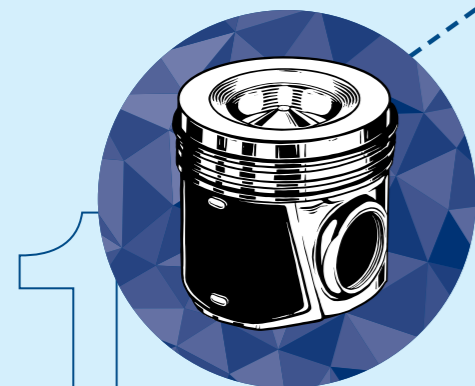

## 1. Engine components

- > Number one piston manufacturer with over 100 years of experience
- > More than 9,000 products

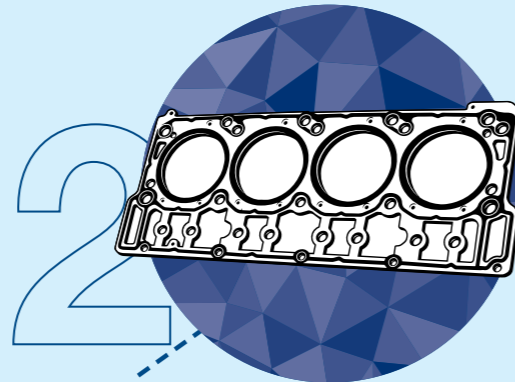

## 2. Gaskets

- > Gaskets for over a million applications cover around 200 million vehicle registrations

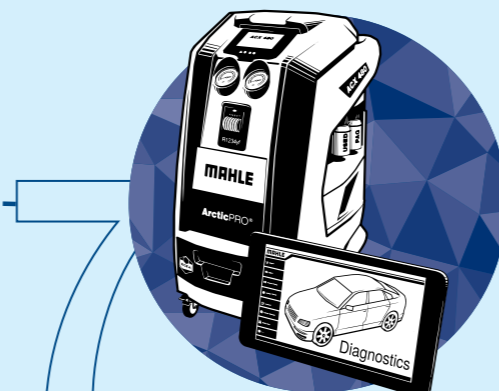

## 7. Workshop equipment & diagnostics

- > Over 30 years of experience in A/C service
- > Innovative and efficient product portfolio
- > Wide range of accessories and support

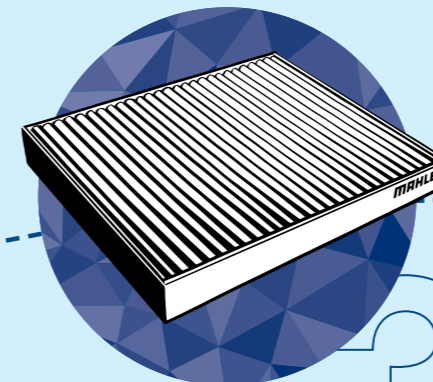

## 3. Filters

- > Number one for market coverage in Europe
- > More than 300 applications for vehicles with alternative drives

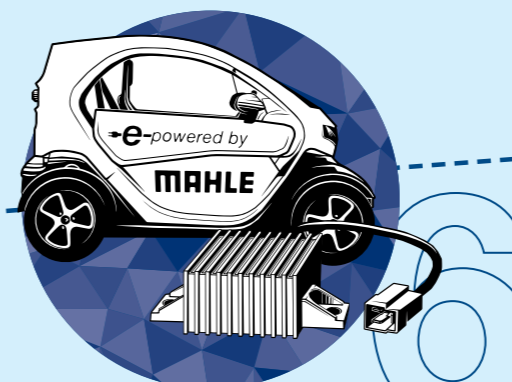

## 6. E-mobility & electronics

- > 48 years of electronics expertise
- > Systems solutions for electric drives, auxiliary components, and thermal management in OE quality

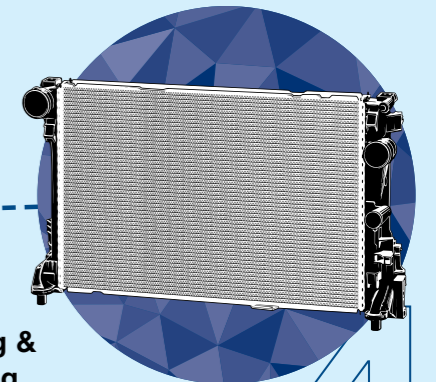

## 4. Engine cooling & air conditioning

- > Unique original equipment competence in thermal management, including air conditioning compressors
- > 9,000 products in 25 product categories, including 4,500 products in PREMIUM LINE quality

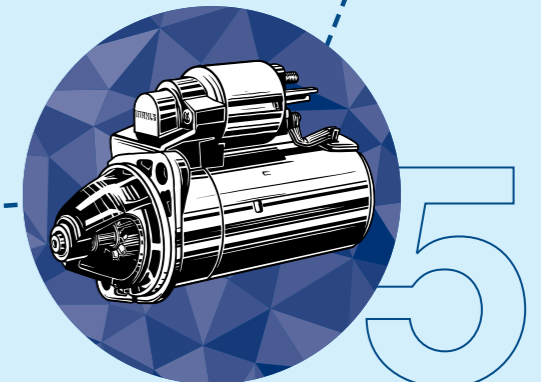

## 5. Starter motors and alternators

- > Over 50 years of experience and knowledge
- > 700 starter motors, 700 alternators, and more than 400 electric drive motors in original equipment quality—plus 5,000 spare parts
- > Over 80% market coverage in Europe

Our original equipment competence is second to none, and not just in air conditioning systems or compressors, which we develop and manufacture globally: MAHLE products are now fitted as standard in at least every second vehicle worldwide. That's why we're always at the cutting edge of technology—and why we know what we're talking about. **We combine this comprehensive know-how with our decades of experience in the service business to provide you with a unique complete package only available from MAHLE: everything in top quality as part of an optimally coordinated system. Real added value for workshop owners and mechanics.**

» GREAT WORK!

# EVERY-DAY HEROES

When the integrated control center of the German Red Cross (DRK) in Böblingen receives an emergency call, things have to move quickly. The rescue teams only have a few seconds to get ready for the journey. And then they're immediately on the road.

The DRK has taken over emergency rescue and patient transport in the Böblingen district—24 hours a day, 7 days a week—on behalf of the state of Baden-Württemberg. The district extends across 618 square kilometers and has around 400,000 inhabitants. To cover the area, the DRK operates four rescue stations in Sindelfingen, Leonberg, Herrenberg, and Malmshheim, where the rescue service vehicles are stationed. "Our vehicle fleet has to be in top shape so that we can fulfill our mission, including compliance with legislation," explains DRK rescue service director Gerhard Fuchs.

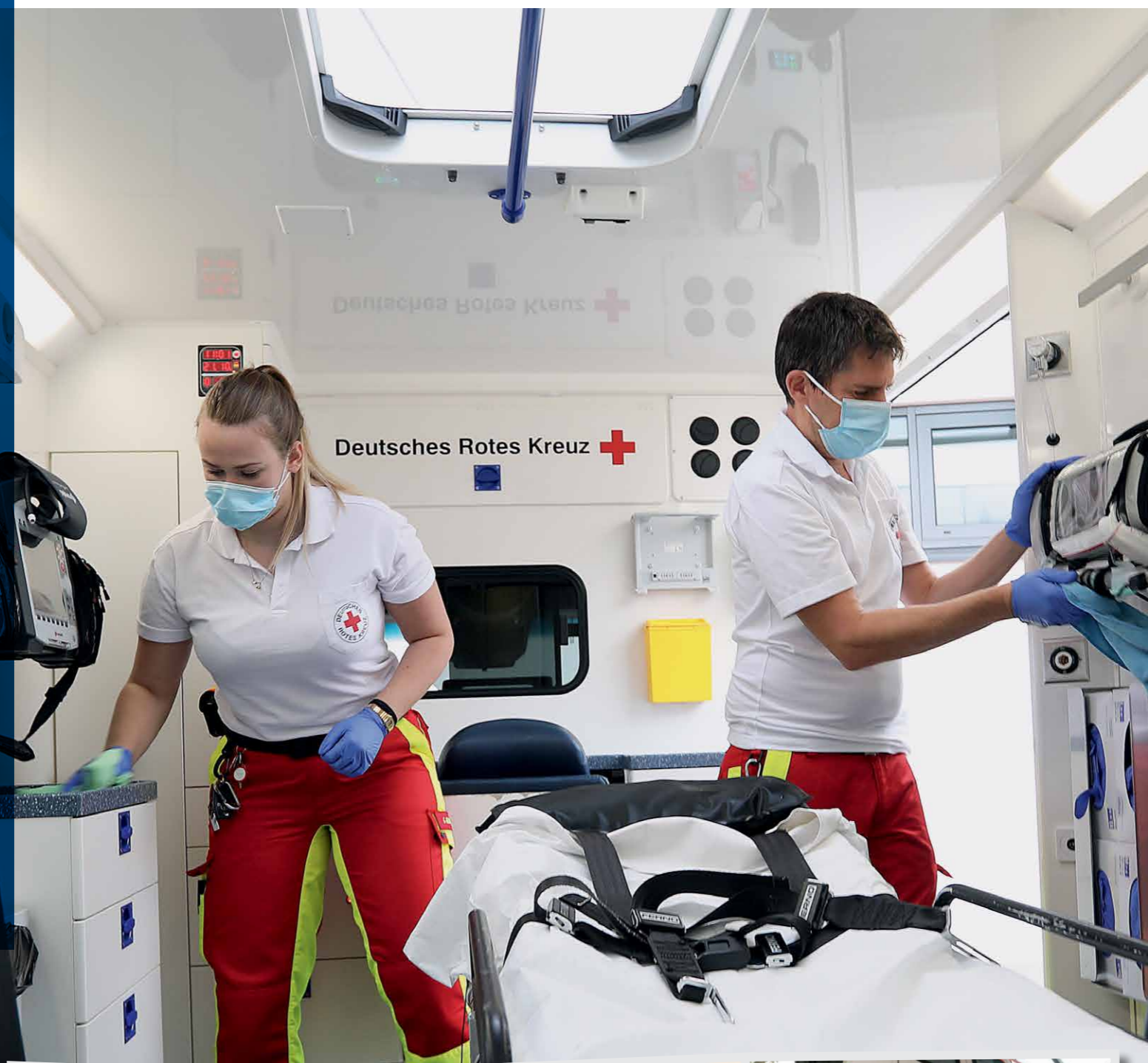

## A SPRINT TO THE VEHICLE

Ambulance services are a key component of the system on which everyone can depend. To guarantee rapid emergency medical care, every movement must be correct, every route must be memorized, and everything must work perfectly. "There is a legally stipulated time limit for assistance, which states that the ambulance must reach the scene of the emergency within 15 minutes in 95 percent of all callouts, regardless of the volume of traffic. In 2019, we were number one in Baden-Württemberg," says Fuchs proudly. To clarify the timings: around 35 seconds after the emergency call is received, the emergency teams are sitting in the vehicle.

The approximately 260 DRK rescue workers in the district of Böblingen attend around 1,300 callouts per month. And to ensure that the ambulances, emergency doctors' vehicles, patient transport vehicles, and the baby emergency ambulance are roadworthy too, the DRK Böblingen district association has its own workshop manager, Werner Klaus. Klaus is a master automotive technician and electrician and is responsible for the entire fleet, which consists of around 30 vehicles and covers well over 400,000 kilometers a year.

## TEAMWORK

Werner Klaus has a challenging task: every vehicle must be ready for use 24/7. And that's no easy feat with four rescue stations spread out across the district. "These are emergency vehicles, and they're treated as such. When human lives are at stake, the equipment must be able to take the strain," explains Klaus. That's why his more frequent tasks include changing brake disks and brake pads. However, Klaus is also qualified to carry out repairs to the vehicle bodies as well as to their electrical and electronic systems.

Of course, Werner Klaus can't look after the fleet all by himself. DRK Böblingen therefore cooperates with a large automotive workshop that carries out regular inspections and tows vehicles away after an accident. "We have a good and very reliable partner that even puts in a night shift if it's really urgent. Together we're doing everything we can to ensure that our rescue vehicles arrive quickly," says Klaus.

**All of us at MAHLE would like to say thank you for this fantastic achievement, day after day! You simply do GREAT WORK.**

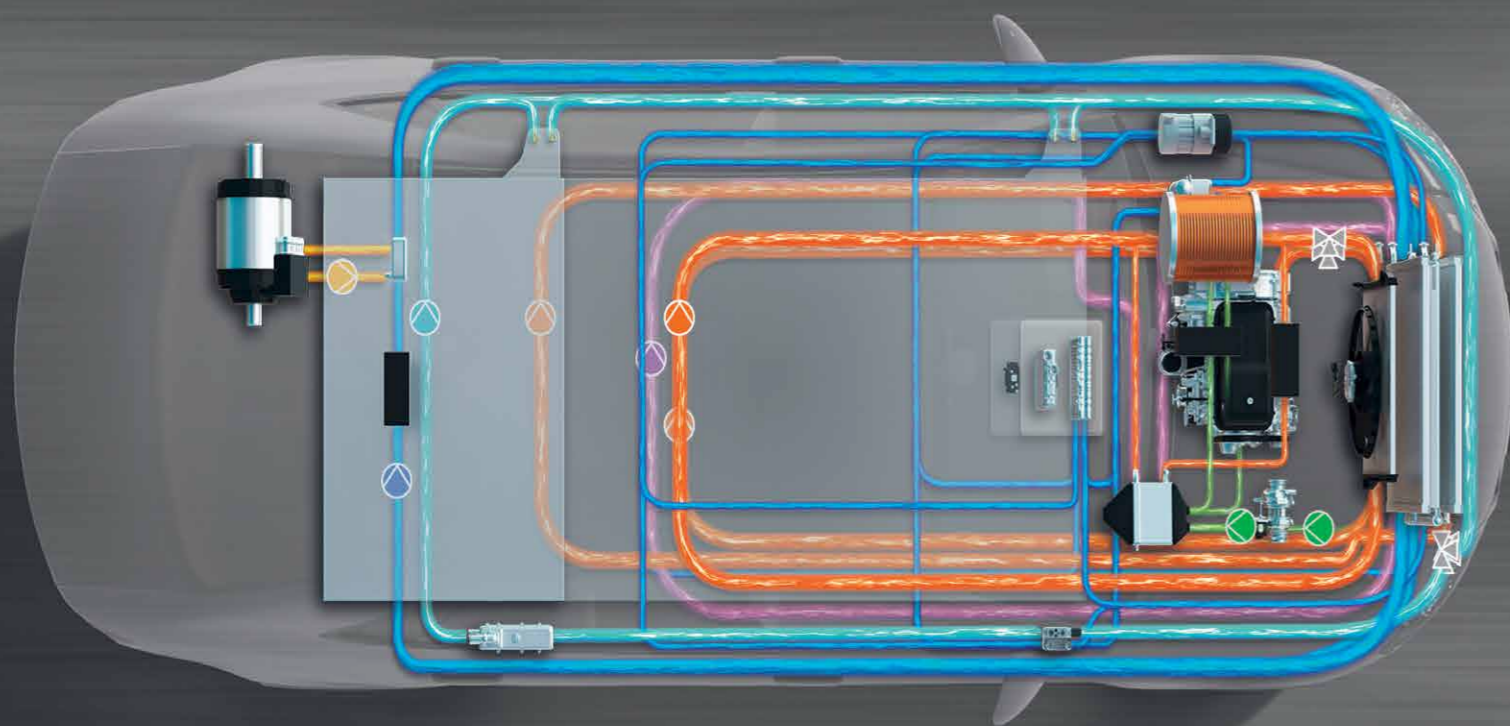

# MORE DRIVES, MORE A/C, MORE SERVICE

**A/C service today, thermal management tomorrow:** The future mix of alternative drive types will increase not only the complexity of work on vehicle cooling and air conditioning systems, but also the need for servicing. With MAHLE, you have a strong partner at your side and receive everything from a single source—developed with complete systems know-how from original equipment, delivered in proven quality. Good for you and your business, good for your customers.



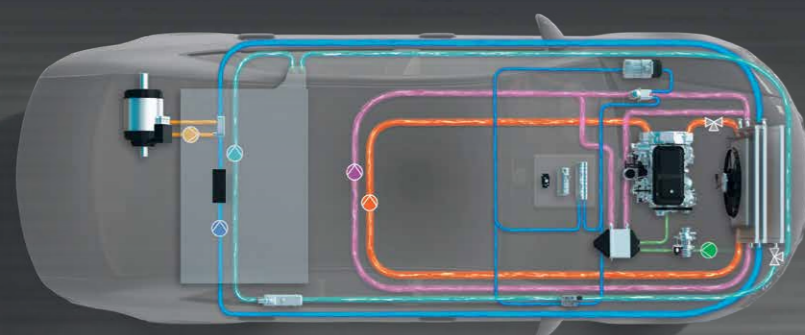

#### › Plug-in hybrid

Lithium-ion batteries require precise temperature control. The air conditioning circuit is therefore becoming an important element of heat management in plug-in hybrids. The use of two separate powertrains leads to several coupled circuits at different temperature levels. To maximize the battery's service life, it must ideally be kept below 40°C. This requires intelligent thermal management.

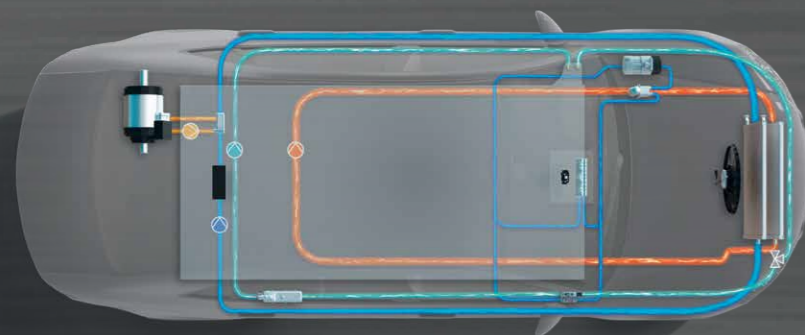

#### › Fully electric drive

In purely electric vehicles, the battery and power electronics take center stage, because optimal temperature control for the battery is directly linked to the cruising range and service life. The fast charging process generates up to 12 kW of heat, which the cooling system has to absorb. Alongside battery cooling, the operation of the interior air conditioning in particular must be as energy efficient as possible.

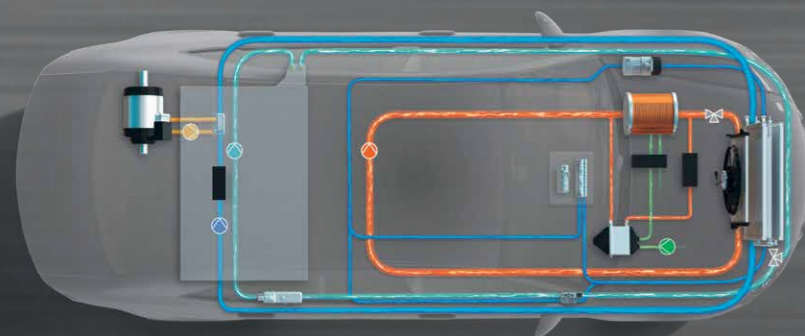

#### › Fuel cell

In vehicles with a fuel cell drive, there's an additional challenge. The amount of heat to be dissipated is comparable to that in combustion engine vehicles. However, the difference between the temperature in the fuel cell and the outside temperature is smaller. This drastically increases the requirements placed on the cooling system.

## » THERMAL MANAGEMENT

# THE NEW DIVERSITY

**Classic combustion engine, plug-in hybrid, purely battery-powered, or fuel cell drive: the future of the powertrain is diverse. And so too are the structure, scope, and function of the cooling and air conditioning systems.**

One thing is clear: with e-mobility, the correct temperature control of the individual components of the drive is extremely important for its service life. The area of battery cooling includes direct cooling, in which an evaporator plate installed in the battery cell is connected to the refrigerant circuit. Indirect battery cooling has several circuits with coolant and refrigerant.

In cold environments, the battery is heated. For this purpose, it is integrated into a secondary circuit that also works with coolant. If the temperature in the battery rises, the heating switches off and the coolant is cooled by the ambient air. If this is not sufficient because the outside temperature is too high, the coolant also flows through a chiller. This works purely mechanically as a kind of evaporator for temperature transfer between the refrigerant and coolant circuits.

#### Evolution of the circuits

The thermal management of combustion engines and electric drives has a similar technical structure. However, the latter is more complex because there are more components and sometimes also several cooling and refrigerant circuits that ensure the correct temperature control of the battery, motor, and power electronics. As the process of electrification continues, regular maintenance of the air conditioning system in the workshop thus helps to preserve its value and contributes to the vehicle's operational reliability.





## » THERMAL MANAGEMENT

# REPLACEMENT IS ABSOLUTELY NECESSARY

## FILTER-DRIER: REPLACE EVERY TWO YEARS!

› The filter-drier has an important task in the air conditioning circuit: It removes dirt particles from the refrigerant, binds moisture, removes bubbles from the condensing refrigerant, and serves as a refrigerant store so that only liquid refrigerant accumulates at the expansion valve.

However, the drier can only absorb a limited amount of moisture. This is why you need to replace it regularly every two years—for example, at the air conditioning service. If it is not replaced, the cooling capacity of the air conditioning system deteriorates until it fails completely.

## If the turbocharger suffers a mechanical defect, you must replace the charge air cooler. Otherwise, there may be expensive consequential damage.

Exhaust gas turbochargers are very much in vogue. They're a key to better engine performance and less fuel consumption, as well as lower pollutant emissions. Nearly every diesel vehicle produced in Europe, North America, or Japan has a turbocharger. And even in gasoline engines—where the keyword is downsizing—the turbo is increasingly coming into play. Turbochargers are therefore also recording strong growth rates in the automotive parts business.

The charge air system is very complex. There are many possible causes of a turbocharger defect, such as damage caused by foreign objects, contaminated oil, a clogged oil filter, interruptions in the oil supply, clogged oil return lines, insufficient oil pressure, or an excessively high exhaust gas temperature. But all causes have one thing in common: they take their toll on the turbocharger—ultimately causing mechanical damage. If this occurs and you need to replace the turbocharger, you must also replace the charge air cooler.

### Why does the charge air cooler need to be replaced?

Among other things, mechanical turbo damage means that the impeller is damaged. This allows metal particles from the

turbocharger to get into the charge air cooler and accumulate there. But the chips and debris can also escape the charge air cooler again and enter the combustion chamber, leading to engine damage. In addition, metal parts that leave the combustion chambers via the exhaust valves can enter the turbine wheel of the new turbocharger. The worst thing about this is that metal particles can also come loose in the charge air cooler, even a long time after turbocharger replacement, and cause damage in the combustion chamber. These are very expensive “delayed effects.” Remember that cleaning or flushing will not reliably remove any chips or metal debris from the damaged turbocharger out of the charge air cooler. It is essential that it is replaced.

### Check components

In addition to the obligatory replacement of the charge air cooler after mechanical turbocharger damage, you should always check all components, inspect the hose lines, and remove contaminants such as metal swarf. This is the only way to prevent another failure of the turbo. And you should always follow the installation instructions of the turbocharger and vehicle manufacturers.

## MAHLE turbochargers

› On the spare parts market, MAHLE offers a wide range of turbochargers for the commercial vehicle sector with more than 70 percent of fast-moving applications. The range is constantly being expanded and a corresponding mounting kit is available for virtually every turbocharger. MAHLE turbochargers are manufactured in line with the highest standards, using the latest processes in state-of-the-art facilities.



» THERMAL MANAGEMENT

# PLEASANT ATMOSPHERE, HAPPY CUSTOMERS

Spring heralds the start of the A/C service season. It's just the right time to get customers into your workshop for an air conditioning check or an air conditioning service. That's because many of your customers aren't aware that a regular A/C service is important for optimal functioning of the air conditioning system. Only a properly maintained air conditioning system can increase safety, prevent mold spores in the air flow and cabin, and avoid damage to the individual components of the air conditioning system. This gives you the chance to demonstrate your competence to customers—and it's good for the workshop business too.



## THE PERFECT DUO

» With MAHLE, you get everything you need for a perfect A/C service—from A/C service units and spare parts to air conditioning compressor oils. You'll also receive plenty of technical support, such as information on the professional replacement of the air conditioning compressor and filling quantities—and this is now also available online. With additional support materials for marketing the air conditioning check, you can get the air conditioning season off to a good start and inform and inspire your customers.

Ask your sales partner about our materials or check out our advertising material shop at: [customer-care.mahle-aftermarket.com](http://customer-care.mahle-aftermarket.com)

## IT'S ALL ABOUT QUANTITY

» When refilling or topping up the vehicle air conditioning system with refrigerant or A/C compressor oil, it's crucial to get the dosage exactly right and use the correct agents. Too little, too much, or the wrong agent will reduce the performance of the air conditioning system. So that you always have access to the exact filling quantities and specifications, there's a convenient online tool in the "Services" area of the MAHLE Aftermarket website, with a database containing the filling quantities of refrigerant and air conditioning compressor oil for cars, vans, and trucks as well as agricultural vehicles. You can look for the exact quantities using a multistep search function and also create favorites for your customers' vehicles.

Access the online tool here: [mahle-aftermarket.com/filling-quantities](http://mahle-aftermarket.com/filling-quantities)



# ALWAYS ON THE BALL

The number and connectivity of driver assistance systems is increasing—even in the low-end vehicle segments—providing greater safety on the road. With MAHLE as your partner, you're always in a prime position to keep pace with this technology and offer your customers a professional service. Safety and health are now also becoming the focus of attention in the vehicle cabin and in your workshop, so MAHLE has added OzonePRO—a mobile device for professional cleaning—to its range. As you can see, we do everything we can to help you do your job to the best of your ability.



## »SERVICE SOLUTIONS

# FAST, PRECISE, DIGITAL, AND ALWAYS UP TO DATE

**Driver assistance systems provide greater safety on the road. That means you need a calibration tool that keeps up with the state of the art: TechPRO® Digital ADAS from MAHLE.**

Many driver assistance systems can now also be found in the compact car segment. With TechPRO® Digital ADAS from MAHLE, you're prepared for the increasing calibration workload, because our tool always keeps you up to date.

**Available in the MAHLE and BRAIN BEE brands**

See how easily and fast you can work with our TechPRO® Digital ADAS. Take a look at the video on our MAHLE YouTube channel.



#### Lower investments

Replacing the windshield, carrying out repairs to the chassis or front end, removing the hood latch support—many jobs make subsequent calibration of sensors and camera systems absolutely essential. With TechPRO® Digital ADAS, you can calibrate the assistance systems of almost any manufacturer and vehicle type. And there's no need for physical calibration panels—it's fully digital. The image of the relevant panel is projected onto the monitor. Not only does this reduce the time spent on the job, the system's database also updates automatically, which means lower costs for you.

#### Guided calibration

The calibration tool from MAHLE is easy and intuitive to use. The TechPRO® or CONNEX diagnostic tool guides you through the entire calibration procedure. On average, calibrating a front camera takes no longer than ten minutes. With MAHLE's digital system, you get exactly the same calibration results as with the vehicle manufacturers' own calibration tools.

#### Fully equipped

TechPRO® Digital ADAS Camera and Radar includes digital calibration panels for front camera systems and a radar mirror for front radar systems. Also part of the package are the electrically height-adjustable car for tools, two laser range finders, two wheel clamps, the 65-inch monitor (including remote control), a mini PC, and a wireless keyboard. Available as accessories: an extensive range of kits and target carpets for 360-degree and rearview camera systems, blind spot assistants and night vision cameras.

## TechPRO® DIGITAL ADAS IS CONSTANTLY BEING DEVELOPED

» These developments include, for example, a lidar calibration panel and a radar reflector for vehicles from the Volkswagen Group.

»SERVICE SOLUTIONS

# INDEPENDENT CLEANING EXPERT

Hygiene in the workshop? Of course! MAHLE's OzonePRO is a new, mobile device for professional cleaning of vehicle cabins, workplaces, as well as larger spaces. The device kills coronaviruses. OzonePRO is also being offered as O3-NEX under the BRAIN BEE sales brand.

Using ozone is a natural way of disinfecting areas contaminated with bacteria, viruses, spores, mold, and mites: it's safe, fast, reliable, fully automatic, and 100 percent environmentally friendly. Our unit consists of a portable generator with a specially designed multifunctional sensor. Besides moisture, temperature, and air pressure, this sensor continuously analyzes the concentration of ozone produced in the vehicle cabin—until the ideal value for optimal cleaning is reached. Inside the unit, corona-effect ceramic plates generate ozone, which is then released into the environment. The sensor ensures that the ozone only remains in the vehicle as long as necessary for the unwanted nasties to be destroyed. OzonePRO is suitable for use in passenger cars, trucks, and buses as well as in offices and workshops.

OzonePRO is extremely simple to use: plug the unit in to the 12 V cigarette lighter socket, place it in the vehicle cabin, press the start button, and close the door—the fully automatic unit does the rest. Once the process is complete, you'll be informed via an acoustic signal and via the app linked to the unit. The time required for the process depends on the volume to be cleaned, the temperature, the humidity, and the composition and cleanliness of the cabin. The unit will also provide a cleaning report, which you can print out for your customer as verification. A first-class service.

#### For indoor spaces too

With OzonePRO you can also clean your workshop professionally and hygienically. An additional power adapter is available for using the OzonePRO unit in indoor areas. With an ozone output of 5,000 mg/h, the unit can sanitize interiors with a surface area of up to 30 square meters or a volume of around 75 cubic meters.

#### Connected

OzonePRO is designed to connect to all the other MAHLE equipment in your workshops via Bluetooth®. So in the future, you will be able to link the unit to the TechPRO® diagnostic tools and ArcticPRO® air conditioning service units. There's also a dedicated app for OzonePRO called O3-Easy, which can be used to control the unit.

## POWERFUL ACTION AGAINST CORONA!

OzonePRO reduces the number of active coronaviruses by 99.683 percent. This has been proven through analysis conducted by Eurofins Biolab Srl, a laboratory certified by the Italian Ministry of Health. All it takes is a cleaning cycle lasting just 35 minutes.

LOUIS RECOMMENDS

# CLEAN PERFORMANCE

Filters are silent stars. Well hidden behind sheet metal or plastic panels, they carry out heavy-duty work for the benefit of the vehicle and its passengers. Filters are also safety products. Your best bet is to rely on MAHLE filters. They offer high quality and a long service life—guaranteeing satisfied customers. In our opinion, filters belong in the spotlight!



Available in the MAHLE and KNECHT FILTER brands

Our product range for vehicles with alternative drives comprises more than 300 filters, and we are gradually expanding it to include additional vehicle models.

## THE FUEL FILTER

› Wins the award for its tireless efforts to keep dirt particles and water away from the injection system. A clogged filter can reduce engine performance, and the vehicle will start to jerk.

**Technical tip:** After changing the filter, you should bleed the fuel system and fill the new filter with fuel before assembly.

## THE OIL FILTER

› This is a silent hero because it not only allows engines to run smoothly, but also ensures they are lubricated. The size of a tin can, it does its job reliably and keeps dirt away from the engine.

**Technical tip:** Always replace the oil filter with the appropriate new gasket. You should also coat the gaskets with fresh engine oil prior to assembly. The silent hero will thank you for it!

## THE CABIN FILTER

› Deservedly at the center of attention, because it keeps the air clean. The filter keeps pollen and fine particulates out, for example, and prevents windows from fogging up. So occupants can breathe deeply at all times.

**Technical tip:** Although clogged cabin filters don't immediately put a vehicle out of action, you should nevertheless encourage your customers to replace them regularly (every year or after 15,000 kilometers). This protects the air conditioner too.

## THE AIR FILTER

› Belongs in the limelight because only clean air ensures an optimal combustion process in the engine. The air filter cleans foreign particles such as dust particles out of the intake air. This prevents wear on the engine components.

**Technical tip:** Make sure that the filter is correctly positioned in the air filter housing. This is the only way to ensure that the engine isn't drawing in unfiltered secondary air.

## THE TRANSMISSION OIL FILTER

› This is a real workhorse because it keeps even complex automatic transmissions performing effectively for a long time. MAHLE transmission oil filters reliably remove abrasion particles from the transmission and thus provide effective protection against damage.

**Technical tip:** Don't just change the oil and transmission oil filters regularly—you should also flush the entire automatic transmission.



# THE LEAN MACHINE

**Light, compact, powerful, smart, and highly integrative: the X35+ e-bike drive system from MAHLE SmartBike Systems is ahead of the pack in a very real sense. More than 20 bicycle manufacturers now rely on our drive.**

You're already familiar with MAHLE's 3D-printed pistons. But an entire 3D-printed steel bicycle frame? Yes, it's true! The bicycle manufacturer Urwahn Engineering is a pioneer in this field, as MAHLE is when it comes to pistons. And for its new, innovative Platzhirsch e-bike, the manufacturer has secured one of the most innovative drive systems on the market: The X35+ from MAHLE SmartBike Systems consists of a wheel hub motor, a battery, and a control unit—and is integrated almost invisibly into the bicycle frame. Rather than follow the trend toward maximum power output, MAHLE offers ideal user-oriented performance. With the X35+, the entire system weighs in at just 3.5 kilograms—making it unique on today's e-drive market. So, at only 14.3 kilograms, the Platzhirsch is still light enough to be slung over its owner's shoulder and carried to the upper floor of an old apartment building.



## > Almost invisible

With a battery that is integrated into the frame and the wheel hub motor, there are hardly any visible signs of electrification. So even e-bikes can look sporty, agile, and stylish. This is particularly advantageous for suppliers of race, gravel, and urban bikes: the Scott Addict eRide, for example, weighs just 10.75 kilograms and is thus the lightest series-produced e-bike in the world. The Spanish manufacturer Orbea also relies on the MAHLE drive system for its high-end Gain race bike. The system cabling for both wheels is fully integrated in the frame.

## > Full connectivity

MAHLE SmartBike Systems bases the development of its e-drive systems on many years of experience in the automotive sector, with numerous bicycle manufacturers relying on MAHLE components. These include compact and lightweight drives such as the X35+, as well as mid-drive motors for mountain bikes. MAHLE is also a pioneer when it comes to connectivity, having developed its own app that interacts with the main components. This allows the cyclist to analyze numerous pieces of information—for example, how far and how fast he or she has ridden, how much electrical assistance was needed during the journey, his or her pulse while cycling, and even cruising range and maintenance requirements. MAHLE's system also gives retailers the option of using an app and an online dashboard to view the status of the bikes they have sold and identify potential problems quickly.

The MAHLE drive unit in the X35+ system supports the rider by seamlessly delivering 250 watts of rated power at the touch of a button. When the battery runs out, the unit offers no resistance, and muscle power can be used for a natural cycling experience. The electric drive is powered by a battery with a capacity of 245 watt hours. An additional range extender battery with a capacity of 208 watt hours is optionally available.

Discover all you need to know about the MAHLE X35+ e-bike drive system online at: [ebikemotion.com-bike](http://ebikemotion.com-bike)



# KING OF THE ROAD: YESTERDAY AND TODAY

#usethebestparts

It all started with light-alloy pistons for engines, and now we're the number one in piston manufacturing. So we can supply you with engine components in original equipment quality, even for classic cars.

For many decades, we've been supplying engine components directly to the production lines of global truck manufacturers—for example, components for the **OM 300 series** from **Mercedes-Benz**. This included several generations of six-cylinder engines, which were mainly produced from 1950 to 1970 to power medium and heavy trucks. At that time, trucks were urgently needed for transporting essential goods, or in road and housing construction.

In 1976, MAHLE developed the first pistons made of cast iron with nodular graphite for truck diesel engines and later engine components for the **Mercedes-Benz Actros OM 501 LA/OM 502 LA series**, which rolled off the production line from 1996 to

2011. With a cooling gallery and ring carrier, the pistons in this series were already much more complex than their predecessors.

One of the major challenges nowadays is to comply with the increasingly stringent exhaust emission standards. And once again, we play our part—with a selection of steel piston concepts, for example.

With over 100 years of development expertise and original equipment competence, we offer a wide range of engine components in OE and OE-matching quality: for vintage models like the OM 300 series and modern classics through the latest truck models, such as the Mercedes-Benz Actros.

## HIGHLIGHTS FROM OUR PRODUCT RANGE:

Engine: OM 355 Series: OM 300

- > Piston (complete) 003 54 00
- > Ring set 003 54 V0
- > Cylinder liner 003 WV 09 00
- > Valve guide (exhaust) 001 FA 30439 000
- > Valve guide (intake) 001 FE 30438 000
- > Valve seat insert (exhaust) 001 SA 30403 000
- > Valve seat insert (intake) 001 SE 30296 000

Engine: OM 542 Series: OM 501 LA/OM 502 LA

- > Piston (complete) 005 26 00
- > Assembly 005 26 92
- > Ring set 005 26 N0
- > Cylinder liner 003 WN 37 00
- > Cylinder liner 003 WN 38 00
- > Exhaust valve 001 VA 30491 000
- > Intake valve 001 VE 30490 000

FIND THE COMPLETE  
PRODUCT RANGE AT:  
[catalog.mahle-aftermarket.com](http://catalog.mahle-aftermarket.com)



# PERFECT CONNECTION

**MAHLE paves the way for e-mobility—now also with a charging cable in original equipment quality. The MX 485 charging cable developed in cooperation with the MAHLE start-up chargeBIG is now available via the usual sales channels.**

Plug into the car, plug into the charging station: charging electric and hybrid vehicles is child's play. A high-quality charging cable, such as the MAHLE MX 485, is a crucial component in this respect. Our cable ensures that electricity flows from the charging station to the vehicle safely and reliably, providing optimal charging power.

Our MX 485 has a type 2 connector according to the EU standard, is robust, and is made of high-quality materials in original equipment quality. This is vital to ensure an optimal, safe charging process. The MX 485 is protected from water spray (protection class IP44) and thus weatherproof, and it is designed for temperatures from  $-30\text{ }^{\circ}\text{C}$  to  $+50\text{ }^{\circ}\text{C}$ .

## THE RIGHT CONNECTION

The (mode 3) MX 485 charging cable has plenty of power. With a charging capacity of up to 22 kW and a three-phase charging current of up to 32 A, it can be used to connect all common electric and hybrid vehicles to charging stations and wallboxes with type 2 connectors (EU standard). And with a length of 5 m, it can be used for charging in (almost) all parking situations.



chargeBIG  
powered by MAHLE



### ELECTRICITY FOR EVERYONE!

It's frustrating when you want to charge your electric vehicle or hybrid but none of the very few charging stations are vacant. In many places, the charging infrastructure still lags behind because independent charging stations and the necessary expansion of the grid connection are expensive. But it can also be done differently, as the MAHLE corporate start-up chargeBIG shows.

The chargeBIG system from MAHLE is an excellent solution for parking lots where electric vehicles are left for relatively long periods of time—as in company parking garages, at airports, in underground garages for large building complexes, and in the case of fleet operators. Instead of charging as quickly as possible, chargeBIG aims to charge as quickly as necessary—with as many electric cars or hybrids as possible being charged simultaneously. With the chargeBIG charging solution, 18 to 100 or more parking spaces can be electrified.

Behind it all is the chargeBIG charging concept that consists of a central control unit with permanently connected cables and connector plugs instead of charging columns in the parking lot. A central control unit distributes the available charging power across the parked vehicles. This centralization and the integrated load management make installation and maintenance much more cost-effective compared with conventional charging systems.

Discover all you need to know about the chargeBIG charging concept online at: [chargeBIG.com](https://chargeBIG.com)

# TEAMWORK: MAN AND MACHINE

If you place an express order for a filter today and it's delivered to you the same day or the next morning at the latest, this is made possible by sophisticated logistics. The central warehouse for the MAHLE spare parts market in Schorndorf, in the Swabian region of Germany, is where everything comes together—now also with the support of autonomous forklifts.

MAHLE's central warehouse operates in two shifts to ensure that all products reach customers around the world quickly and reliably. Around 1,000 pallets and 250 express deliveries leave the location every day. Intelligent and highly efficient logistics are necessary to ensure that everything runs smoothly and, most importantly, without errors. Seven autonomous, driverless forklifts now support the busy facility in Schorndorf.



## CENTRAL WAREHOUSE IN FIGURES

- > 44,000 m<sup>2</sup>
- > Includes 17,000 m<sup>2</sup> of filter storage
- > 1,000 pallet deliveries per day
- > 250 express deliveries per day



### ON THE SAME TRACK

The automation of the warehouse began with four autonomously operating narrow-aisle forklifts in the high-bay warehouse for filter products. Here, they independently carry out around 1,000 operations a day. They were joined by three unmanned reach trucks that operate “in the wild”—a first for the MAHLE Group. What's special about the autonomous reach trucks in Schorndorf is that they don't need laser reflectors or tracks embedded in the floor. This is because they use geonavigation to orient themselves using fixed points such as shelves. To ensure that people and unmanned machines can use the same routes in the 17,000-square-meter filter warehouse, there is extensive laser- and camera-based safety equipment.

### MAN AND MACHINE

Safety and reliability have top priority in the warehouse. Therefore, all processes had to be checked, optimized, and standardized before the autonomous forklifts could be used. This means, for example, that only goods on perfectly formed pallets can be delivered. If the conditions are right, the forklifts work almost as productively and reliably as their human colleagues. But in uncertain situations, such as when a pallet has been moved, human experience still beats the machine.

# NEW ON THE MARKET

We're constantly expanding our extensive offering for workshops. Here we present a small selection of our new products. They're easy to order through the online catalogue at [catalog.mahle-aftermarket.com](http://catalog.mahle-aftermarket.com).

#usethebestparts

## » PISTON

**Vehicle type:**  
Trucks

**Engine:**  
DC 09.108, DC 09.111,  
DC 09.112, DC 09.113

**Manufacturer:**  
Scania

**Vehicle models:**  
P 250, P 280, P 320, P 360, G 280,  
G 320, G 360, HD 250, HD 280,  
HD 320, HD 360, LD 250, LD 280,  
LD 320, LD 360, MD 250, MD 280,  
MD 320, MD 360

**Part no.:**  
061 PI 00140 000



MAHLE

## » CABIN FILTER

**Vehicle type:**  
Passenger cars

**Manufacturer:**  
Opel

**Vehicle models:**  
Crossland X 1.2, X 1.5, X 1.6

**Part no.:**  
LAK 1517



MAHLE

## » OIL FILTERS

**Vehicle type:**  
Passenger cars

**Manufacturer:**  
Porsche

**Vehicle models:**  
718 Boxster, Cayman

**Part no.:**  
OX 1218D



MAHLE

## » RING SET

**Vehicle type:**  
Trucks

**Manufacturer:**  
Volvo, DAF

**Vehicle models:**  
Compressor

**Part no.:**  
037 RS 10010 0N0



MAHLE

## » AIR FILTER

**Vehicle type:**  
Passenger cars

**Engine:**  
DPCA, DADA, DFYA, DHFA

**Manufacturer:**  
Audi, Seat, Skoda, VW

**Vehicle models:**  
A1, A2, Q2, Q3, Arona, Ateca, Ibiza,  
Leon, Karoq, Kodiaq, Octavia,  
Superb, Golf, Passat, Polo, Tiguan

**Part no.:**  
LX 4398/1



MAHLE

## » THERMOSTAT

**Vehicle type:**  
Passenger cars

**Engine:**  
BAR, BSM, BVJ, BXA

**Manufacturer:**  
Audi, VW

**Vehicle models:**  
A6, A8, Q7, Touareg 4.2/5.2 FSI

**Part no.:**  
TM 23 95



BEHR

## » EVAPORATOR

**Vehicle type:**  
Trucks

**Manufacturer:**  
Volvo

**Vehicle models:**  
FH II series

**Part no.:**  
AE 169 000P



BEHR

## » FILTER (UREA FILTER)

**Vehicle type:**  
Trucks

**Manufacturer:**  
Mercedes-Benz, Kamaz

**Vehicle models:**  
Actros MP2/MP3, Atego II,  
Axor II, Econic, 5000/6000 Series

**Part no.:**  
UX 3KIT



MAHLE

## » CLASSIC LINE PISTON

**Vehicle type:**  
Passenger cars

**Engine:**  
M 100

**Manufacturer:**  
Mercedes-Benz

**Vehicle models:**  
450 SEL

**Characteristic features:**  
Returning to the range

**Part no.:**  
003 17 00  
003 17 01 (1st oversize)



MAHLE

## » ROD/MAIN/THRUST BEARING

**Vehicle type:**  
Passenger cars

**Engine:**  
OM651

**Manufacturer:**  
Mercedes-Benz

**Vehicle models:**  
A 180 CDI, A 200 CDI,  
C 220 BLUETEC, CLS 250 CDI

**Part no.:**  
001 PL 21831 000  
001 HL 21956 000  
001 FL 21834 000



MAHLE

# AFTERBURNER

Latest reports, hot topics, and electrifying news.

## And action!

If you're not yet familiar with it, you should fix that immediately: the Technical Messenger from MAHLE provides technical information and tips on all aspects of the maintenance and repair of MAHLE products. To make it even easier for you, there are now regular videos on selected Technical Messenger topics. You can find them on the **Instagram channel** of **MAHLE MPULSE**, on **Facebook**, and on some of our **regional Instagram channels**. So, subscribe now and never miss a Messenger again.

 Technical  
Messenger



## Taking part pays off

Automotive professionals help automotive professionals—that's the idea behind FabuCar, the professional platform for professional technicians. Those who really go the extra mile should be rewarded. And Roland Biberger of the Meisterhaft workshop Autohaus Biberger in Münchsmünster is one of them. He has already used the video platform to help his colleagues solve difficult problems on 70 occasions, putting him at the top of the ranking list. As a reward, we've presented him with a MAHLE e-bike worth EUR 3,500.

## We want to say THANK YOU!

Still in its infancy, but already extremely popular among workshops, amateur mechanics, and car enthusiasts: The **MAHLE MPULSE Instagram channel** has reached the milestone of **10,000 followers**. This shows that the mix of topics, including motorsports, technical tips, interactive campaigns, product information, and a whole lot of emotion, is an effective one. Because we want to communicate with you in a meaningful way, we've also set up eight other **MPULSE country channels (USA, Poland, Russia, Brazil, UK, South Africa, Mexico, and South America)**.



 **MPULSE ONLINE:**  
**MPULSE.MAHLE.COM**

## MAHLE gets you in shape!

With our **online training courses**, we now make it even easier and more convenient for everyone interested to acquire the full package of **MAHLE know-how**. The online offering currently includes our theory training courses on filtration, thermal management, air conditioning in vehicles, starter motors and alternators, combustion engines, turbochargers, and new technologies. Interested? Ask your MAHLE Aftermarket trading partner or contact us directly at [ma.training@mahle.com](mailto:ma.training@mahle.com).



## IMPRINT

PUBLISHED BY:  
MAHLE Aftermarket GmbH  
Pragstraße 26-46  
70376 Stuttgart/Germany  
[mahle-aftermarket.com](http://mahle-aftermarket.com)

RESPONSIBLE FOR CONTENTS:  
Olaf Henning

EDITORIAL MANAGEMENT:  
Elena Barth

OTHER AUTHORS:  
Stefan Auch, Jörg Laukenmann, Jonathan Pfeiffer,  
Sophie Kalmbach, Andrea Anania, Andrea Savi,  
Christopher Rimmle, Simon Kolmstetter,  
Thomas Bauer, Karl-Heinz Nicolai, Nicole Heinrich,  
Seyma Evrem, Alexander Wagner, Himanshu Sharma,  
Katrin Frick, Jan Reichenbach, Sebastian Goldbach,  
Patrick Jennert, Michael Forler

TEXT:  
Jan Peters, Communication Consultants GmbH

DESIGN:  
FACT GmbH advertising agency | [www.fact.agency](http://www.fact.agency)

FOREIGN LANGUAGE MANAGEMENT:  
Target Languages GmbH

PHOTOGRAPHS:  
MAHLE GmbH, Stuttgart/Germany;  
MAHLE Aftermarket GmbH, Stuttgart/Germany;  
MAHLE International GmbH, Stuttgart/Germany;  
P. 2 © Thomas Dashuber;  
Pp. 3/20/21 © vejaa/stock.adobe.com;  
Pp. 3/20/21 © LIGHTFIELD STUDIOS/stock.adobe.com;  
Pp. 3/28/29 © Daniel Geiger; © Martin Steffen;  
© SCOTT Sports SA;  
Pp. 24/25 © Feydzhet Shabanov/stock.adobe.com;  
P. 27 © Werbefotografie Blühdorn;  
Pp. 28/29 © freedom\_wanted/stock.adobe.com;  
Pp. 30/31 © m.photo/stock.adobe.com;  
Pp. 34/35 © challenge GmbH;  
P. 38 © abasler/stock.adobe.com;  
Back page © DS TECHEETAH

PRINT:  
Kohlhammer Druck

FREQUENCY OF PUBLICATION:  
Semiyearly in March and September

Should you no longer wish to receive MPULSE, you can revoke your agreement concerning the usage of your personally identifiable information for advertising purposes at any time, with effect for the future. To do this, please send a brief message to [mpulse@mahle.com](mailto:mpulse@mahle.com).

All rights reserved. Reproduction and publication in any form, including in electronic media and/or in the form of extracts, is only permitted with the express written consent of MAHLE Aftermarket GmbH. For more information and authorized copies, contact your personal MAHLE sales partner.



# Strong e-partnership

## From motorsports to series production

MAHLE Motorsports has already been a developer and systems partner on the international motorsports scene—including Formula 1—for several decades. These activities are also a catalyst for technological developments that can subsequently be put into series production. Starting this season, MAHLE is a technical partner to leading Formula E team DS TECHEETAH. Here once again, the competitive motorsports environment is ideal for testing our own solutions for tomorrow's e-mobility.

[mahle.com](https://www.mahle.com)

**MAHLE**